

GXE350-NG

Natural Gas Genset

Standard Basic Module

- Highly efficient gas engine
- AC synchronous alternator
- Gas safety train
- Cooling system suitable for ambient temperature up to 50°C
- Advanced engine control system, including: ignition system, speed control system, air/fuel ratio control system
- Strict shop test for all gensets
- Industrial silencer reduces the noise by 12-20dB(A)
- Integrated the control & switch cabinet
- Data communication interfaces integrated into control system
- Bus interface for connecting to higher level control unit



Structure and Control Cabinet

Structure Type	Open type
Spraying Process	High quality powder coating
Electrical control cabinet	Integrated, IP54
Noise level @ 1m, dB(A)	101
@ 7m, dB(A)	89.7
@ 10m, dB(A)	83.8

Electric data @50Hz

Voltage-V	Power-kW	Efficiency-%	Current-A
380	350	38.8	665
400	350	38.8	631
415	350	38.8	609
440	350	38.8	574

Dimension and Weight

Dimension (LxWxH) , mm	5200X2000X2100
Weight, kg	6400

Fuel and emission

Fuel type	Natural gas
Methane number	MN > 80
Excess air factor (Lambda)	1.45
Fuel consumption @ 100% load, m ³ /h	95
Supply gas pressure range (gage pressure), kPa	10~20
Emission without catalytic converter	
NO _x , mg/Nm ³	<500mg/Nm ³
CO, mg/Nm ³	<650mg/Nm ³
HCHO (formaldehyde) , mg/Nm ³	<60mg/Nm ³
NMHC, mg/Nm ³	<150mg/Nm ³
Emission with catalytic converter(optional)	
NO _x , mg/Nm ³	≤250 mg/Nm ³

Special statement:

- 1、The technical data is based on natural gas with a lower calorific value of 34.2MJ/Nm³. The technical data indicated is based on standard conditions according to ISO8528/1, ISO3046/1 and BS5514/1.
- 2、The technical data is measured in standard conditions:
Absolute atmospheric pressure: 100kPa
Ambient temperature: 25°C
Relative air humidity: 30%
- 3、Rating adaptation at ambient conditions acc to DIN ISO 3046/1.
The tolerance for the specific fuel consumption is + 5 % at rated output.
- 4、Technical data above are just for standard product ,and may be subject to change. As this document is used only for presale reference, take the specification supplied by PowerLink before ordering as final.



GXE350-NG

Natural Gas Genset

Standard Basic Module + Soundproof (Optional)



Dimension and Noise Level

Canopy Size	5400*2050*2500mm
Noise Level@ 1m, dB(A)	86.9
@ 7m, dB(A)	75.2
@ 10m, dB(A)	70.2

- Modular designed and manufactured for plug and play
- Environmental friendly low emission
- Small indoor space required for installation
- Low noise does not affect the surrounding environment



GXE350-NG

Natural Gas Genset

POWERink
Power Systems
Power Link the World

Standard Basic Module + Container (Optional)



Dimension and Noise Level

Optional container (mm)	<input type="checkbox"/>	6058*2438*2591
(customized container modeling service available)	<input type="checkbox"/>	12192*2438*2896
	<input type="checkbox"/>	12192*3000*2896
Noise Level@ 1m, dB(A)		84
@ 7m, dB(A)		73
@ 10m, dB(A)		68

- Outdoor application enabled, weatherproof and dustproof, corrosion preventive Environmental friendly low emission
- Modular designed and manufactured for plug and play Low noise does not affect the surrounding environment



GXE350-NG

Natural Gas Genset

Genset performance data and manufacturing technology

Genset model	GXE350-NG	Telephone interference factor(TIF)	≤50
Frequency(Hz)	50	Telephone harmonious factor(THF)	≤2%, as per BS4999
Electrical output power (kW)	350	Manufacturing technology <ul style="list-style-type: none">● Special welded base frame, inner vibration isolators and design for whole lifting● With high-class coating, enduring brightness as well resistance against abrasion and defacing● Installation manual, operation and maintenance manual wiring program Standards and certificate <ul style="list-style-type: none">● ISO3046, ISO8528, GB2820● BS5000PT99, AS1359, IEC34● ISO9001:2008 quality system certification	
Genset electrical efficiency	38.8%		
Overload runtime at 1.1xSe(hour)	1		
Steady-state voltage deviation	±1%		
Transient-state voltage deviation	-15%~20%		
Voltage recovery time(s)	≤4		
Voltage unbalance degree	1%		
Steady-state frequency regulation	±0.5%		
Transient -state frequency regulation	±5%		
Frequency recovery time(s)	≤3		
Steady-state frequency band	0.5%		
Recovery time response(s)	0.5		

Gas engine

Brand	PowerLink	Energy balance and gas flow	
Model	GX20T-LE01	Mechanical power (kW)	400
NO. of cylinders	6	Coolant heat (kW)	199
Bore x Stroke (mm)	152x180	Radiation heat max. (kW)	31
Displacement (L)	19.6	Exhaust heat up to 120°C (kW)	230
Cooling system	Water cooled	Fuel Input (kW)	902
Rated speed (rpm)	1500	Combustion air flow(kg/h)	1894
Intake system	Turbocharged, intercooled	Exhaust gas flow(kg/h)	2018
Lube Oil consumption(kg/h)	0.105	Exhaust gas temperature(°C)	492
Combustion type	Lean burn	Gas consumption(m³/h) @100% load	95
Battery voltage(V)	24	75% load	71
Coolant type	Glycol mixture	50% load	49

AC alternator

Brand	PowerLink	Wiring connection	Star
Model	PL5S	Rotor insulation class	H
Rated output power @400V (kW)	400	Winding pitch	2/3
Power factor	0.8	A.V.R. model	MX341
Rated current @400V (A)	722	Voltage fluctuation(no load to full load)	± 0.5%
Excitation system	PMG	Drip proof	IP23
THF (BS EN60034- 1)	<2%	Excitation method	Brushless
TIF (NEMA MG 1-22)	<50	Rated ambient temperature(°C)	40
Winding material	100% copper	Rated stator temperature rise(°C)	125

GXE350-NG

Natural Gas Genset

POWERink
Power Systems
Power Link the World

PLC500

PARALLEL GEN-SET CONTROLLER



APPLICATION OVERVIEW

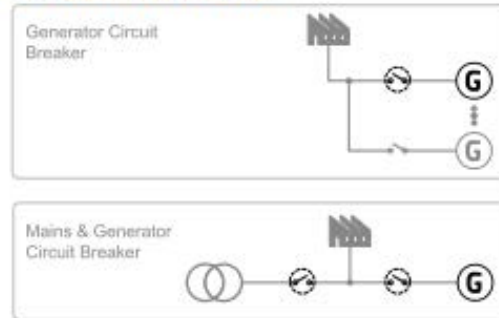

PRODUCT DESCRIPTION

- Comprehensive paralleling gen-set controller
- Parallel operation for up to 32 gen-sets
- Direct communication with ECU
- Remote control and monitoring
- Flexible, extendable, yet user friendly

KEY FEATURES

- Multiple Island or Single Parallel to Mains applications both in one controller
- PLC support with PLC editor and monitor
- Perfect solution for rental applications:
 - Rental timers
 - Geofencing and tracking via Web Supervisor
 - Alternative configuration
 - Droop and Emergency droop
- Load sharing and VAr sharing via CAN
- Wide communication capabilities including
 - Integrated USB for configuration
 - Isolated RS485 port on board for MODBUS
 - Integrated USB Host for uploading/ downloading FW/Configuration with USB key
 - Integrated Ethernet port
- High accuracy of voltage and current measurement
- Cloud-based monitoring and control
- Active SMS and emails in different languages
- Up to 5 languages in the controller
- Configurable MODBUS (User MODBUS)
- Support of MODBUS RTU/TCP or SNMP v1/v2c
- Detailed history with up to 500 events
- Load shedding, dummy load capability
- Tier 4 Final support
- Automatic temperature based cooling/heating
- Comprehensive gen-set protections
- Multipurpose flexible timers with full calendar
- True RMS measurement

Standard configuration

Version: A2.0

2023/02

GXE350-NG

Natural Gas Genset

Engine	Alternator	Canopy and base	Electrical cabinet
Gas engine Ignition system Lambda controller Speed control system Electrical start motor Battery system Detonation control system Cylinder temp. protection system Lockable isolator switch Turbocharger & intercooler	AC alternator H class insulation IP23 protection AVR voltage regulator PMG	Steel monocoque base frame Engine bracket Vibration isolators Alternator base	PLC500 control system LCD screen Main circuit breaker Electrical switch cabinet Communication interfaces Mains float charger
Gas supply system	Lubrication system	Standard voltage	Induction/ exhaust system
Gas safety train Air/fuel mixer Throttle valve	Oil filter Daily auxiliary oil tank New and used oil tank (Only applicable to container , two inch with the daily oil tank)	380/220V 400/230V 415/240V 440/254V	Air filter Exhaust silencer Exhaust bellows Gas leakage protection(Only applicable to canopy and container)
Cooling system	Service and documents		
Intercooler radiator Circulation coolant pump	Tools package Installation and operation manual Maintenance manual Software manual Parts manual	Engine operation and maintenance manual Gas quality specification Control system manual After service guide Standard package	

Optional configuration

Engine	Alternator	Lubrication system
Jacket water radiator Jacket water heater	Space heater Treatments against humidity and corrosion	
Electrical system	Gas supply system	Service and documents
RCD ATS control cabinet Thermal power gauge Electric power gauge	Gas flow gauge	Service tools Maintenance and service parts
Voltage	Exhaust system	Exhaust gas using
220V 230V 240V	Three-way catalytic converter	Exhaust gas evaporator LiBr refrigerator