

Standard Basic Module -Open Type

- Highly efficient gas engine
- AC synchronous alternator
- Gas safety train
- Cooling system suitable for ambient temperature up to 50°C
- Advanced engine control system, including: ignition system, speed control system, air/fuel ratio control system
- Strict shop test for all gensets
- Industrial silencer reduces the noise by 12-20dB(A)
- Integrated the control & switch cabinet
- Data communication interfaces integrated into control system
- Bus interface for connecting to higher level control unit



Structure and control cabinet

Structure Type	Open
Spraying Process	High quality powder coating
Electrical control cabinet	Integrated, IP54
Noise level@1m, dB(A)	100
@7m, dB(A)	91.1
@10m, dB(A)	86.9

Dimension and weight

Dimension (LxWxH) , mm	3345×1180×1718
Weight, kg	2710

Special statement:

1. The technical data are based on natural gas with a lower calorific value of 34.2MJ/Nm³. The technical data indicated is based on standard conditions according to ISO8528/1, ISO3046/1 and BS5514/1.
2. The technical data is measured in standard conditions:
Absolute atmospheric pressure: 100kPa
Ambient temperature: 25°C
Relative air humidity: 30%
3. Rating adaptation at ambient conditions acc to DIN ISO 3046/1. The tolerance for the specific fuel consumption is + 5 % at rated output.
4. Technical data above are just for standard product ,and may be subject to change. As this document is used only for presale reference, take the specification supplied by PowerLink before ordering as final.

Electric data @50Hz

Voltage-V	Power-kW	Efficiency-%	Current-A
380	200	35.7	380
400	200	35.7	361
415	200	35.7	348
440	200	35.7	328

Fuel and emission

Fuel type	Natural gas
Methane number	MN >80
Excess air factor (Lambda)	1.4
Fuel consumption @100% load, m ³ /h	59
Supply gas pressure range (gage pressure), kPa	10~20
Emission without catalytic converter	
NO _x , mg/Nm ³	< 500mg/Nm ³
CO, mg/Nm ³	< 650mg/Nm ³
HCHO (formaldehyde) , mg/Nm ³	< 60mg/Nm ³
NMHC, mg/Nm ³	< 150mg/Nm ³
Emission with catalytic converter(optional)	
NO _x , mg/Nm ³	≤250 mg/Nm ³

Standard Basic Module + Acoustic Attenuated Canopy (Optional)



Dimension and Noise Level

Canopy Size	3500*1450*2050mm
Noise Level@ 1m, dB(A)	80.2
@ 7m, dB(A)	72.9
@ 10m, dB(A)	68.9

- Modular designed and manufactured for plug and play
- Environmental friendly low emission
- Small indoor space required for installation
- Low noise does not affect the surrounding environment



GXE200-NG

Natural gas Genset

Standard Basic Module + Acoustic Attenuated Container (Optional)



Dimension and Noise Level

Optional container (mm) (customized container modeling service available)	<input type="checkbox"/>	7000*2300*2500
	<input type="checkbox"/>	6058*2438*2591
	<input type="checkbox"/>	12192*2438*2896
	<input type="checkbox"/>	12192*3000*2896
	<input type="checkbox"/>	13500*3000*2896
	<input type="checkbox"/>	15000*3200*3000
Noise Level@ 1m, dB(A)		78
@ 7m, dB(A)		70
@ 10m, dB(A)		66

- Outdoor application enabled, weatherproof and dustproof, corrosion preventive Environmental friendly low emission
- Modular designed and manufactured for plug and play Low noise does not affect the surrounding environment



Genset performance data and manufacturing technology

Genset model	GXE200-NG	Telephone interference factor(TIF)	≤50
Frequency(Hz)	50	Telephone harmonious factor(THF)	≤2%, as per BS4999
Electrical output power (kW)	200	<p>Manufacturing technology</p> <ul style="list-style-type: none"> ● Special welded base frame, inner vibration isolators and design for whole lifting ● With high quality paint, enduring brightness as well resistance against abrasion and defacing ● Installation manual, operation and maintenance manual circuit diagram <p>Standards and certificate</p> <ul style="list-style-type: none"> ● ISO3046, ISO8528, GB2820 ● BS5000PT99, AS1359, IEC34 ● ISO9001:2008 quality system certification 	
Genset electrical efficiency	35.7%		
Overload runtime at 1.1xSe(hour)	1		
Steady-state voltage deviation	≤±1%		
Transient-state voltage deviation	-15%~20%		
Voltage recovery time(s)	≤4		
Voltage unbalance degree	1%		
Steady-state frequency regulation	±0.5%		
Transient -state frequency regulation	±5%		
Frequency recovery time(s)	≤3		
Steady-state frequency band	0.5%		
Recovery time response(s)	0.5		

Gas engine		AC alternator	
Brand	PowerLink	Brand	PowerLink
Model	GX12T-LE01	Model	PL4MS
NO. of cylinders	6	Rated output power @400V (kW)	235
Cylinders arrangement	In line	Power factor	0.8
Bore x Stroke (mm)	126x155	Rated current @400V (A)	424
Displacement (L)	12.0	Excitation system	PMG
Cooling system	Water cooled	THF (BS EN60034- 1)	<2%
Rated speed (rpm)	1500	TIF (NEMA MG 1-22)	<50
Rated output power (kW)	230	Winding material	100% copper
Excess air factor	1.40	Wiring connection	Star
Intake system	Turbocharged, intercooled	Rotor insulation class	H
Lube oil consumption (kg/h)	0.060	Winding pitch	2/3
Combustion type	Lean burn	A.V.R. model	MX341
Battery voltage	24V	Voltage fluctuation(no load to full load)	± 0.5%
Coolant type	Glycol mixture	Housing protection	IP23
Gas consumption(m³/h)@ 100%load	59	Brushless	Brushless
75%load	44	40	40
50%load	31	125	125

PLC500

PARALLEL GEN-SET CONTROLLER



APPLICATION OVERVIEW

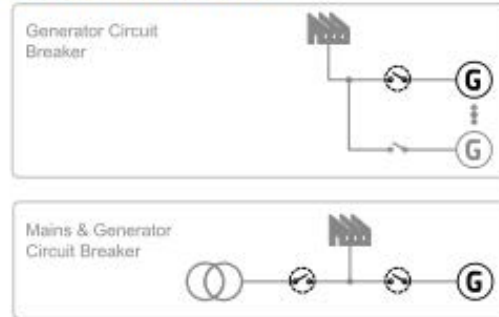

PRODUCT DESCRIPTION

- Comprehensive paralleling gen-set controller
- Parallel operation for up to 32 gen-sets
- Direct communication with ECU
- Remote control and monitoring
- Flexible, extendable, yet user friendly

KEY FEATURES

- Multiple Island or Single Parallel to Mains applications both in one controller
- PLC support with PLC editor and monitor
- Perfect solution for rental applications:
 - Rental timers
 - Geofencing and tracking via Web Supervisor
 - Alternative configuration
 - Droop and Emergency droop
- Load sharing and VAR sharing via CAN
- Wide communication capabilities including
 - Integrated USB for configuration
 - Isolated RS485 port on board for MODBUS
 - Integrated USB Host for uploading/ downloading FW/Configuration with USB key
 - Integrated Ethernet port
- High accuracy of voltage and current measurement
- Cloud-based monitoring and control
- Active SMS and emails in different languages
- Up to 5 languages in the controller
- Configurable MODBUS (User MODBUS)
- Support of MODBUS RTU/TCP or SNMP v1/v2c
- Detailed history with up to 500 events
- Load shedding, dummy load capability
- Tier 4 Final support
- Automatic temperature based cooling/heating
- Comprehensive gen-set protections
- Multipurpose flexible timers with full calendar
- True RMS measurement

Standard configuration

Engine	Alternator	Canopy and base	Electrical cabinet
Gas engine Ignition system Lambda controller Speed control system Electrical start motor Battery system Detonation control system Cylinder temp. protection system Lockable isolator switch Turbocharger & intercooler	AC alternator H class insulation IP23 protection AVR voltage regulator PMG	Steel monocoque base frame Engine bracket Vibration isolators Alternator base	PLC control system LCD screen Main circuit breaker Electrical switch cabinet Communication interfaces Mains float charger
Gas supply system	Lubrication system	Standard voltage	Induction/ exhaust system
Gas safety train Air/fuel mixer Throttle valve	Oil filter Daily auxiliary oil tank New and used oil tank (Only applicable to container , two inch with the daily oil tank)	380/220V 400/230V 415/240V 440/254V	Air filter Exhaust silencer Exhaust bellows Gas leakage protection(Only applicable to canopy and container)
Cooling system	Service and documents		
Circulation coolant pump Intercooler radiator	Tools package Installation and operation manual Maintenance manual Software manual Parts manual	Engine operation and maintenance manual Gas quality specification Control system manual After service guide Standard package	

Optional configuration

Engine	Alternator	Lubrication system
Jacket water heater	Space heater Treatments against humidity and corrosion	Auto refilling oil system
Electrical system	Gas supply system	Service and documents
RCD ATS control cabinet Thermal power gauge Electric power gauge	Gas flow gauge	Service tools Maintenance and service parts
Voltage	Exhaust system	Exhaust gas using
220V 230V 240V	Three-way catalytic converter	Exhaust gas evaporator LiBr refrigerator